

595-193-E
2005-05-03

Manual for **FURLING MAST ELECTRIC**



 **SELDÉN**

Contents

Contents.....	2
INTRODUCTION.....	4
About the Manual.....	4
1 SYSTEM DESCRIPTION.....	5
1.1 General Description.....	5
1.2 The Furling System.....	6
1.3 ELECTRIC - technical overview.....	7
1.4 12 or 24V.....	7
1.5 Checklist.....	8
1.6 Electrical Block Diagram.....	10
1.7 Components/Functions - Description.....	10
1.7.1 Battery.....	10
1.7.2 Power Fuse and Battery Cable.....	11
1.7.3 Maneuver Supply Fuse.....	11
1.7.4 Maneuver Supply Switch.....	11
1.7.5 Control box.....	11
1.7.6 MAIN IN- and MAIN OUT-buttons.....	11
1.7.7 IN- and OUT-button Light Switch.....	12
1.7.8 Junction Box.....	12
1.7.9 Motor Unit.....	12
1.7.10. Light output (max.50W).....	13
1.7.11 Remote Control.....	13
2. INSTALLATION.....	14
2.1 Electrical Circuit Diagram.....	14
2.2 Cable Installation.....	15
2.2.1 Cables through Deck.....	15
2.2.2 Between control box and junction box.....	16
2.2.3 From control box to MAIN IN-and MAIN OUT-buttons.....	18
2.2.4 From control box to cabin control panel.....	19
2.2.5 From mast to junction box.....	19
3 OPERATION.....	20
3.1 Test and setup.....	20
3.1.1 Testing Rotation Direction.....	20
3.1.2 Testing the Emergency Gear.....	21
3.1.3 Fitting and Hoisting the Sail.....	21
3.1.4 Furling the sail.....	21
3.2 Un-furling and Furling the sail.....	21
3.2.1 Un-furling.....	21
3.2.2 Furling.....	21
3.2.3 Reefing.....	22
3.2.4 Outhaul line.....	22
3.2.5 Topping Lift (Spare Main Haulyard) and Kicking Strap.....	22
3.2.6 Emergency Gear - components.....	23
3.2.7 Manual Operation (Emergency Operation).....	24
3.2.8 Manual Operation, Un-furling in light winds.....	26
4 MAINTENANCE.....	27
4.1 Top and halyard swivel.....	27
4.2 Furling mast ELECTRIC –.....	27
motor unit and emergency gear house.....	27
4.2.1 Periodic maintenance.....	27

4.2.2 Greasing.....	27
5 INSTALLATION OF A RETRO-FIT FURLING MAST ELECTRIC	28
5.1 Preparations	28
5.1.1 Checklist	29
5.1.2 Tools	29
5.2 Definitions	30
5.2.1 Definition of B-line	30
5.2.2 Definition of directions.....	30
5.3 Dismounting the manual gear.....	30
5.4 Using the template	31
5.5 Cutting out for the Furling Mast ELECTRIC.....	33
5.6 Cutting out for the emergency handle socket	35
5.7 Cutting out for the torsion pin	36
5.8 Access hole for greasing the bearing.....	37
5.9 Access hole for the clevis pin.....	38
5.10 Prepare for the cable sealing (keelstepped masts only).....	38
5.10.1 Standard procedure	38
5.10.2 Cables emerging above deck on a keelstepped mast.....	39
5.11 Cutting the torsion pin of the emergency gear house	40
5.12 Mounting the motor unit.....	40

INTRODUCTION

About the Manual

To obtain the maximum benefit and enjoyment from your Seldén FURLING MAST ELECTRIC we recommend that you study this manual carefully.

The manual is divided into four sections. One is a GENERAL DESCRIPTION of system and of the included electrical and mechanical parts. The second section is dealing with INSTALLATION (the electrical components) of a system mounted on a new furling mast, and the third one describes how to OPERATE the system. The fourth section is about MAINTENANCE, and finally the fifth section describes installation of a FURLING MAST ELECTRIC unit on an F-mast already equipped with a Seldén manual furling system.

This manual is a supplement to the “Manual for Furling Mast TYPE RA” (595-059-E) and “Manual for Furling Mast TYPE RB Mk II/RC Mk II” (595-063-E). The appropriate manual is included in your FURLING MAST ELECTRIC-documentation. To install and operate the system both this manual and the actual manual mentioned above, are required.

This manual covers FURLING MAST ELECTRIC RA(12V), RB(12V), RC(12&24V).



This symbol indicates that the information is safety related.

1 SYSTEM DESCRIPTION

1.1 General Description

Seldén FURLING MAST ELECTRIC is an electrically operated motor driven system for furling and reefing the mainsail. The design is based on Seldén's long experience with in-mast furling systems and earlier versions of electrical furling systems. FURLING MAST ELECTRIC has been engineered to ensure simplicity and reliability.

The system can be fitted in Seldén's new furling mast range (F194 – 305 & R324). For this range of masts it is also possible to exchange a manual furling gear for the FURLING MAST ELECTRIC (retro-fit).

Operation is controlled from the cockpit where the IN- and OUT-buttons are mounted. The sail is set and furled on a luff extrusion in the mast's sail compartment. The luff extrusion is located between the output shaft of the FURLING MAST ELECTRIC unit and a top swivel at the masthead.

The luff extrusion is tensioned and has an asymmetric profile. These features reduce friction both when unfurling and furling the sail.

FURLING MAST ELECTRIC consists of two main parts. The first one is the motor unit connected to the luff extrusion, which is mounted inside the mast. The other one is the control box which is installed below deck.

To prevent the sail from unfurl, when it's reefed, the unit is equipped with a permanently loaded brake. The brake is released automatically when the OUT- or IN-button is pushed.

On top of the motor there is an emergency gear. This is normally not engaged.

All FURLING MAST ELECTRIC systems are supplied with an emergency handle. The dimension of the handle socket is the same as for a standard 1/2" socket wrench.

The FURLING MAST ELECTRIC system shares some parts (luff extrusion, top- and halyard swivel) with Seldén's manual in-mast furling system. A copy of the manual and a spare part list is included with your mast.

The cables coming with the motor, as well as the cables we deliver as optional equipment, are all tin coated for better resistance against corrosion.

For information on rigging and tuning the mast, please refer to the Hints and advice booklet from Seldén Mast.

1.2 The Furling System

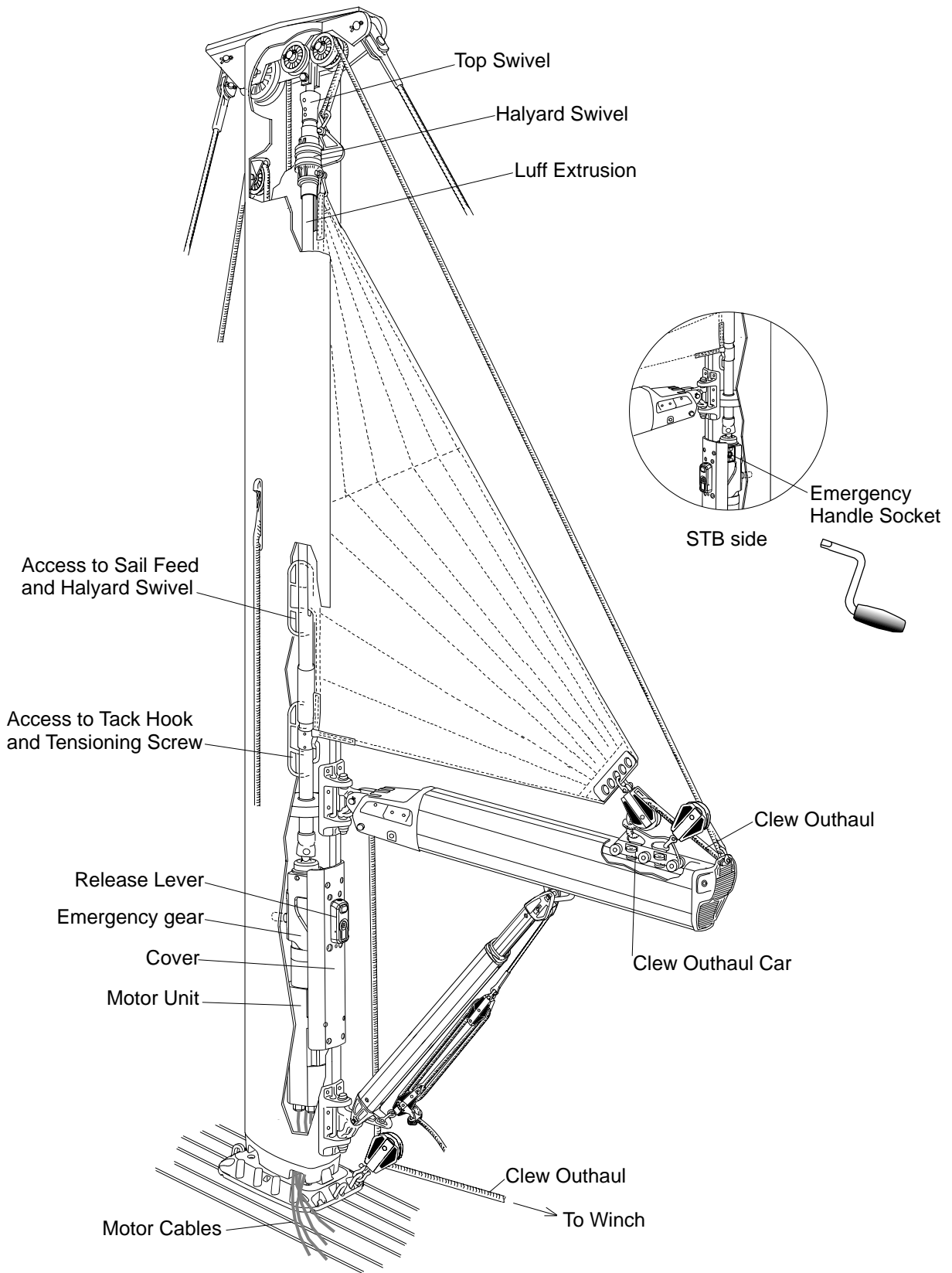

1.3 ELECTRIC - technical overview

In the table below, please find the different available combinations of mast sections, system size (RA, RB, RC) and voltage for FURLING MAST ELECTRIC.

Mast Section Size (mm)	12V			24V
	RA	RB	RC	RC
F194	YES	–	–	–
F212	YES	–	–	–
F228	YES	YES	–	–
F246	–	YES	–	–
F265	–	YES	YES	YES
F286	–	–	YES	YES
F305	–	–	YES	YES
R324	–	–	YES	YES





1.4 12 or 24V

The 12 or 24V is mostly decided by the standard alternator fitted to the engine of the boat. 24V will give lower current drain and allow longer cable runs/ less cable areas.

1.5 Checklist

The FURLING MAST ELECTRIC has been factory installed in your furling mast. The following parts are supplied loose with your mast (control-pack).

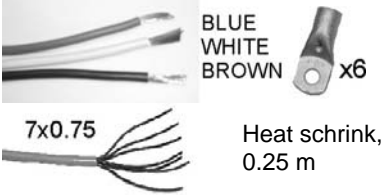
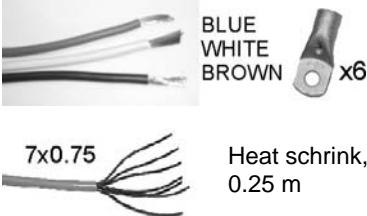
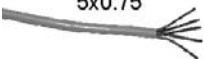
Y	Description	Qty	Seldén part number/ notes
<input type="checkbox"/>	Control box 	1	532-505
<input type="checkbox"/>	Junction Box 	1	532-300-02
<input type="checkbox"/>	Junction kit  x8	1	532-435-01
<input type="checkbox"/>	Emergency handle 	1	533-922
<input type="checkbox"/>	Pushbutton switches 	1	540-459-02 (MAIN OUT) 540-460-02 (MAIN IN)
<input type="checkbox"/>	Protection hose, black 		319-670 1m length For deckstepped masts only
<input type="checkbox"/>	Lubricating Grease 90g-HAZ	1	312-501
<input type="checkbox"/>	Manual Electric In-Mast Furling		595-193-E
<input type="checkbox"/>	Manual for Furling mast TYPE RA and TYPE RB/RC	1	595-059-E 595-063-E
<input type="checkbox"/>	Manual Spare Parts List RA/RB/RC	1	595-110-E

OPTIONAL EQUIPMENT			
<input type="checkbox"/>	Panel for one switch, stainless 		540-461-01
<input type="checkbox"/>	Panel for switches, stainless 		540-462-01
<input type="checkbox"/>	Power cable kit 16 mm ²  7x0.75 Heat shrink, 0.25 m	BLUE WHITE BROWN x6	531-026-03.....531-026-10 The last two figures indicate length, 531-026-05=5m etc Cable 1 according to inquiry form 595-194
<input type="checkbox"/>	Power cable kit 25 mm ²  7x0.75 Heat shrink, 0.25 m	BLUE WHITE BROWN x6	531-029-03.....531-029-10 The last two figures indicate length, 531-029-05=5m etc Cable 1 according to inquiry form 595-194
<input type="checkbox"/>	Pushbutton control cable  5x0.75		531-032 (We deliver 7x0.75 mm ² , use only 5 cores) Cable 2 according to inquiry form 595-194 Length according to inquiry form 595-194
<input type="checkbox"/>	Cabin panel control cable  2x0.75		531-034 Cable 3 according to inquiry form 595-194 Length according to inquiry form 595-194

1.6 Electrical Block Diagram

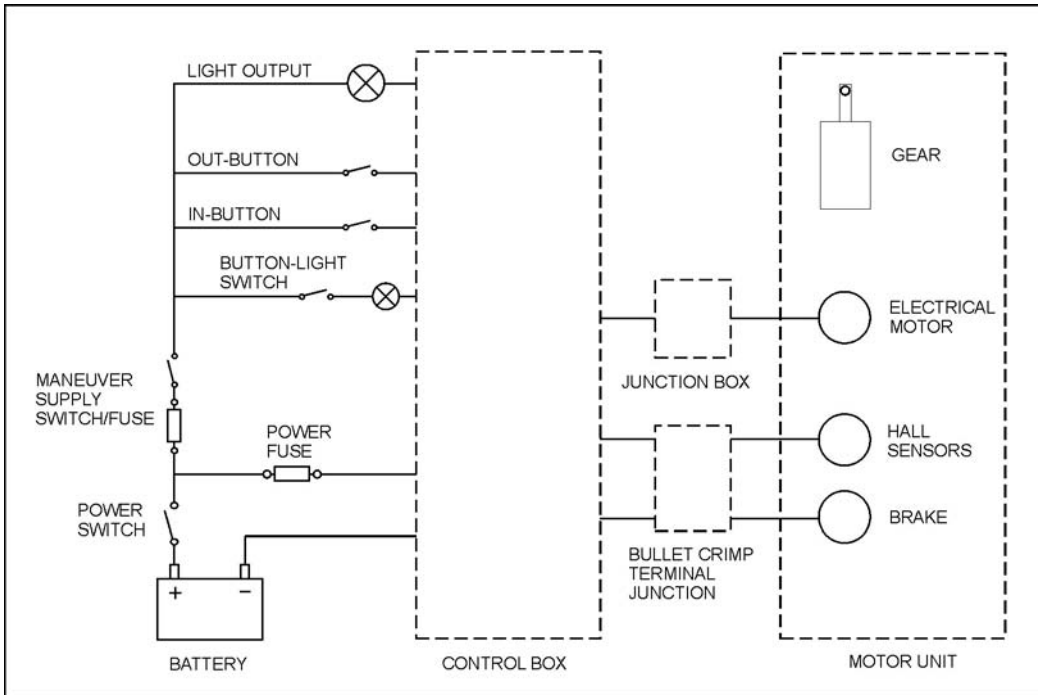

The block diagram shows the principle of Seldén FURLING MAST ELECTRIC system. Most of the components are supplied by Seldén (see component/ function description below). For installation, please refer to the “Electrical Circuit Diagram”, chapter 2.1.

1.7 Components/Functions - Description

1.7.1 Battery

(Not supplied by Seldén)

The table below shows Seldén’s recommended minimum battery capacity for operation of FURLING MAST ELECTRIC. Depending on other users supplied from the same battery, the capacity might have to be increased. Do not use the starting battery.

Recommended minimum battery capacity (Ah)	12V			24V
	RA	RB	RC	RC
	60	60	2 x 60	60

1.7.2 Power Fuse and Battery Cable

(Not supplied by Seldén)

This fuse is for protection of the cables between battery and control box. To have the appropriate cable area respectively amperage value for the power fuse, please refer to the table below.

Voltage	12V			24V
System	RA	RB	RC	RC
Power Fuse (A)	80	125	160	125
Cable (mm ²) length<8m	16	25	35	25
Cable (mm ²) length>8m	25	35	50	35

Power Fuse and Battery Cable

1.7.3 Maneuver Supply Fuse

(Not supplied by Seldén)

The maneuver circuit should be protected by a 6 Amp fuse.

1.7.4 Maneuver Supply Switch

(Not supplied by Seldén)

The switch should be mounted in the cabin control panel. When the switch is in “off” position, it’s not possible to run the motor.

1.7.5 Control box

The control box limits the maximum torque and controls the speed of the motor. The speed of the outgoing shaft (and of the luff extrusion) is approximately 40 rpm.

If the maximum torque is reached, the current is automatically cut, the motor stops and the brake is engaged. After about two seconds the power is automatically reset and the motor may be operated again.

The control box case is made from an anodized aluminum profile. To avoid overheating, the case profile includes cooling flanges to dissipate excess heat.

In normal operation, the sail is furled in less that one minute. If the motor is run at maximum load for approximately 5 minutes, the maximum temperature (85°C) is reached. The current will be cut automatically. The system will not operate until the temperature has fallen.

1.7.6 MAIN IN- and MAIN OUT-buttons

The push buttons should be easily accessible by crew in the cockpit. If it’s difficult to find a convenient place for the buttons, install them close to the helmsman and use a remote control for the FURLING MAST ELECTRIC crew.

The buttons are equipped with internal light (see 1.6.7)

The buttons can be mounted with or without Seldén’ stainless steel switch panel (OPTIONAL EQUIPMENT), for one or two buttons. For mounting dimensions of buttons and panels, see chapter 2.

1.7.7 IN- and OUT-button Light Switch

(Not supplied by Seldén)

The switch should be mounted in the cabin control panel. When the switch is in “on” position, the MAIN IN- and MAIN OUT-buttons are illuminated by internal lights.

1.7.8 Junction Box

The motor is supplied from new with 4 x 5 m cables. All cables exit via the mast base. On a deckstepped mast, the cables extend by 3.5 m. On a keelstepped mast, the extra is 1.5 m. Use the Junction Box for the three 16mm² power cables. Fit Ø8.4 ring crimp terminals (for M8 bolt,) on the three cables.

The junction box should be fitted below deck. Make sure that the riggers can easily identify the box when the mast is unstepped at a later date.

The seven cores in the fourth cable are connected by bullet crimp terminals.

For main dimensions of the junction box please refer to the sketch.

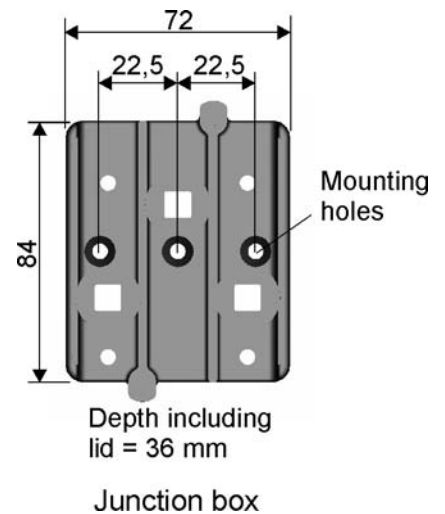

1.7.9 Motor Unit

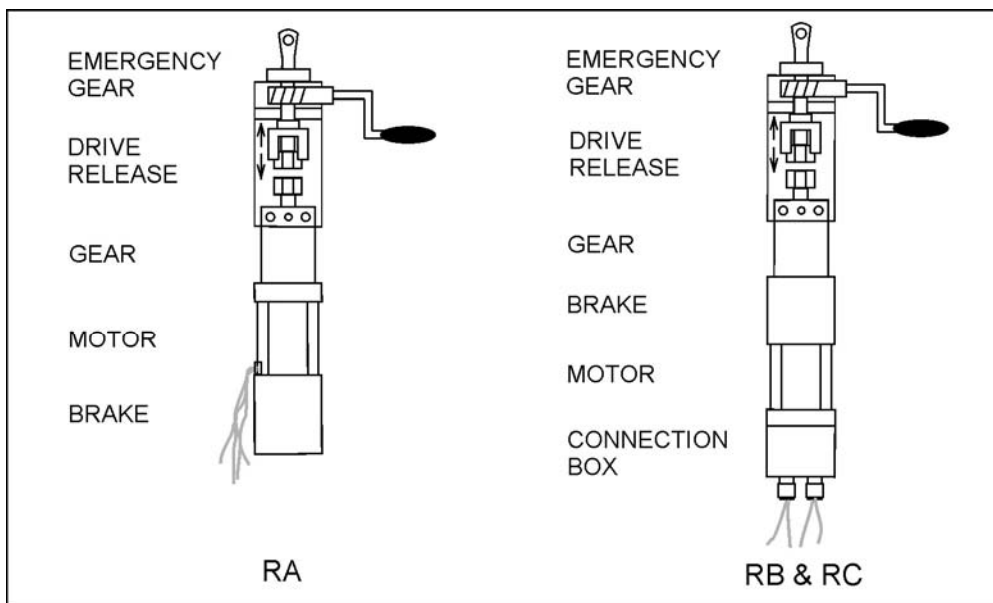

Motor unit layout

Connection Box

RB- and RC-units are equipped with a connection box, for the cables, at the rear end of the motor. On a RA-unit the cables comes from the side of the motor.

Brake

The RC-unit is equipped with a permanent magnetic brake and the RA- and RB - units have a spring loaded brake. The brake prevents the sail unfurling when it is reefed, or furled inside the mast.

The brake is normally loaded. It is unloaded when, and only when, MAIN IN- or MAIN OUT-button is pushed and the motor is running.

Motor

The electrical motor is a brush-less, permanent magnetic, synchronous motor. The rotor is wound for 12 or 24 V. For commutation and speed control, the position of the rotor is detected via three Hall-sensors.

Gear

The gearbox is of planetary type, and it has a ratio of 51:1. The holding torque is transferred from the sail profile, through the gearbox, and into the brake either directly or via the motor shaft (RA).

Drive Release

The release lever (the black handle facing aft on mast) releases the sail profile from the output shaft of the gearbox. When it's released, the profile can be turned by hand. See below.

Emergency Gear

Insert the emergency handle socket on starboard side, near top of the unit, and push it towards the centre of the mast. The emergency worm gear will now be engaged. When engaged, the gear is self-locking, and prevents the sail unfurling. For detailed information on how to operate the emergency gear, see chapter 3.

1.7.10. Light output (max.50W)

In the control box there is an output for a light to illuminate the sail entry (or elsewhere) when using the furling system. The light output is powered when one of the IN- or OUT-buttons is pushed. It is automatically cut off 7 seconds after the push button is released. If installing a light, choose one with a 50 W bulb (maximum).

1.7.11 Remote Control

It is possible to use a remote control together with the FURLING MAST ELECTRIC. The control should have two functions (normally open contacts) which are connected parallel to the MAIN OUT- and MAIN IN-button respectively.

2. INSTALLATION

2.1 Electrical Circuit Diagram

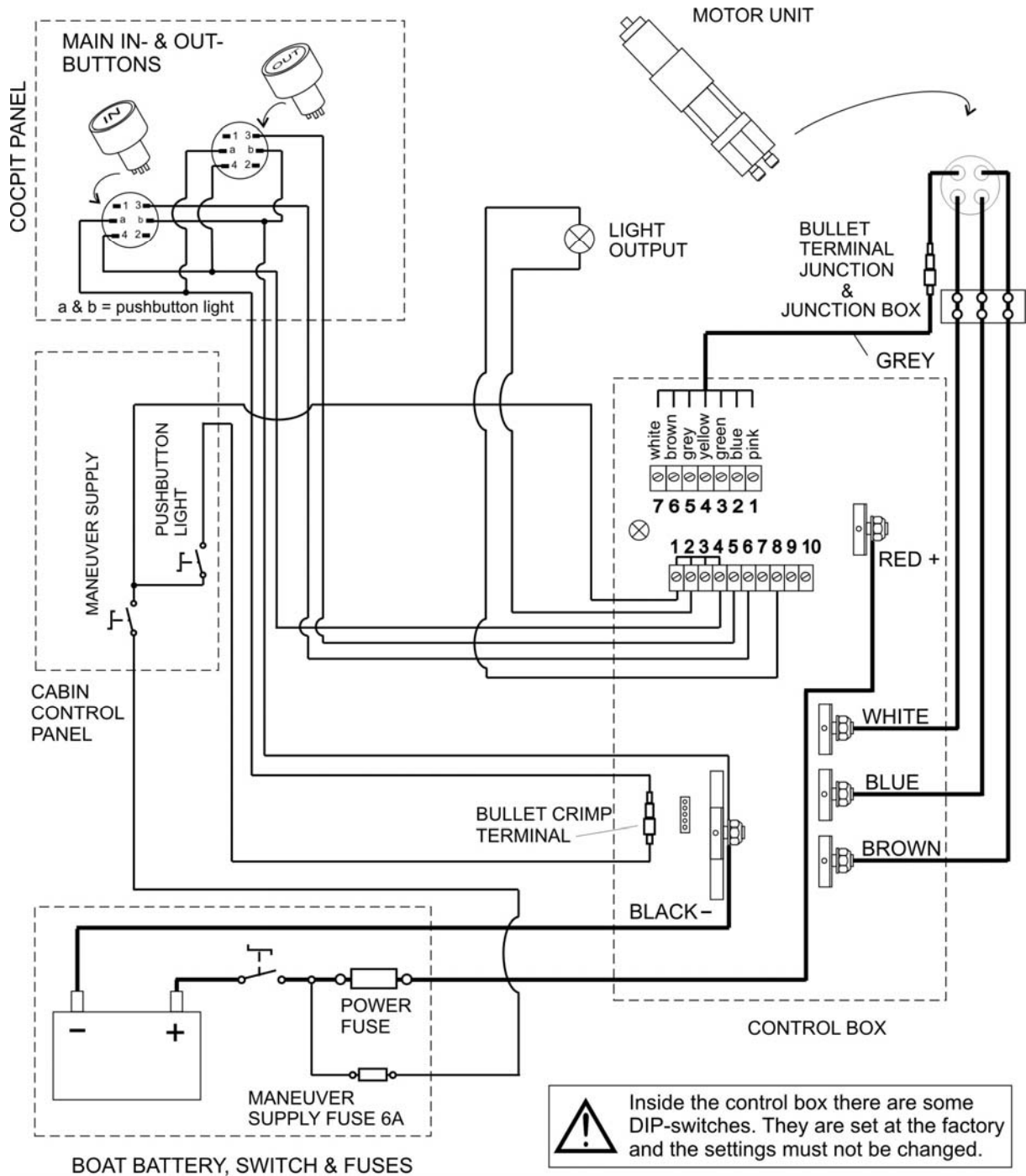

2.2 Cable Installation

Keep the length of all cables to a minimum and secure them properly with cable clips or cable ties. Make sure that there are no sharp edges on fittings or interior furniture that could cut the insulation.

Note the free length of the four motor cables when deciding where to put the junction box.

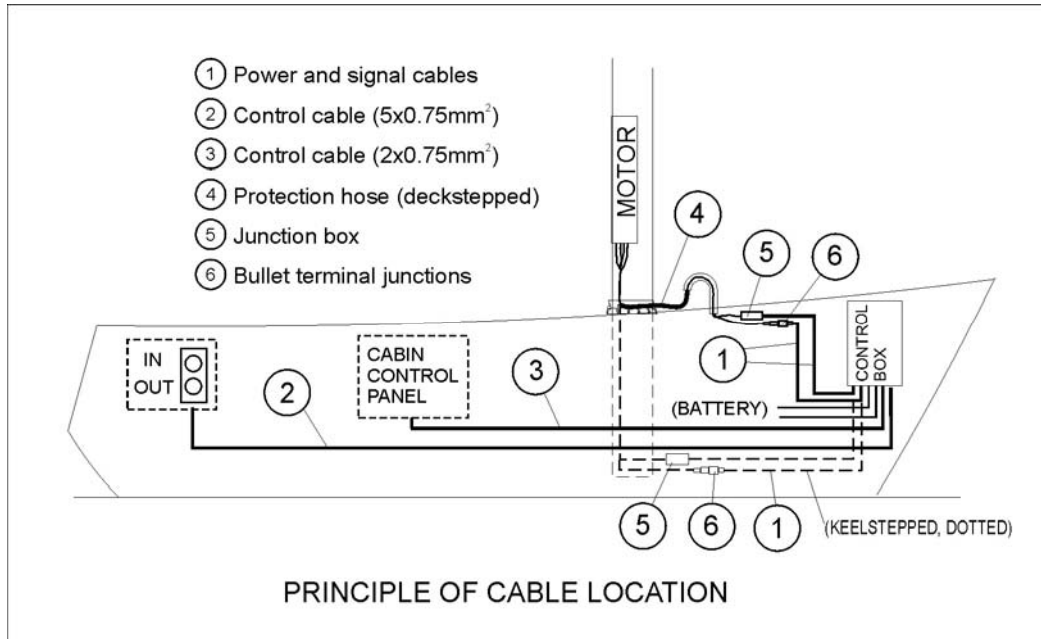

2.2.1 Cables through Deck

Deckstepped Mast

The four motor cables emerge through the mast heel. Lead them through a swan-neck to the junction box below deck. To protect the cables, between the mast heel and the swan neck, use the included protection hose. Free length of cables emerging from the base of a deckstepped mast is 3.5 m.

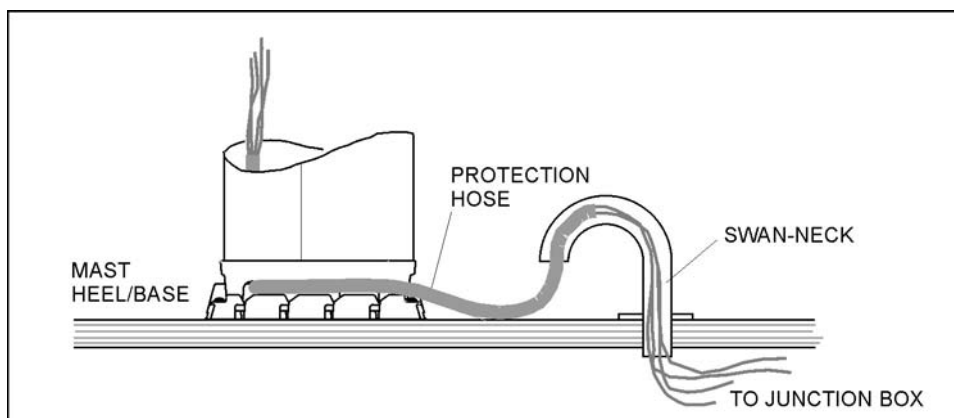

Keelstepped Mast

The cables are led through the mast internal seal. This lead-through is watertight and it's easy to dismount if the motor has to be taken out of the mast. Free length of cables emerging from the base of a keelstepped mast is 1.5 m.

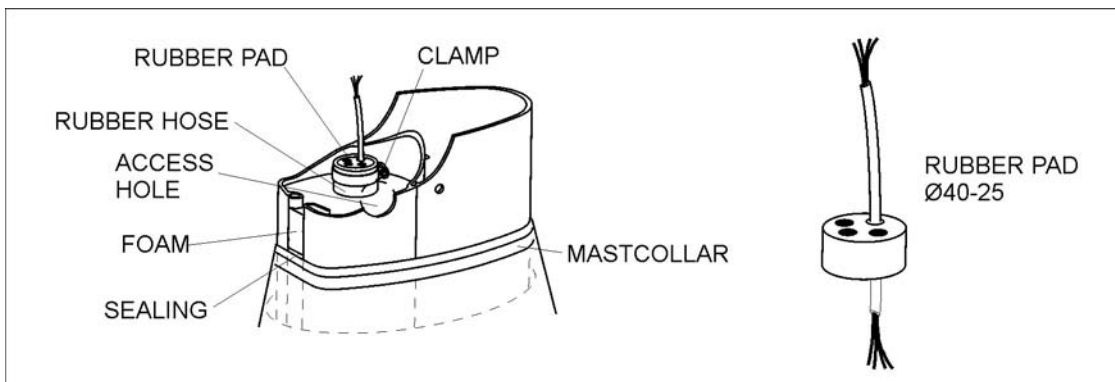

2.2.2 Between control box and junction box

Install the junction box for the three power cables below deck, near the swan-neck (deckstepped) or near the mast base (keelstepped). Make sure that the box is mounted above possible bilge water level.



Junction box; power cables with ring crimp terminals and heat-shrinkable tubes.

Install the control box vertically, in a dry place. Make sure that you have access to the control box from top- and bottom-side. All cables enter the control box from below. For main dimensions of the control box, refer to the illustration beside. Refer to the table below to select the appropriate cable area for the actual length of the power cables between control box and junction box. Lead the cables from the control box to the junction box and secure them. Use ring crimp terminals (Ø8.4mm) and heat-shrinkable tubes for the power cables at junction box end. Use the same type of terminals (Ø6.5 or Ø8.4mm) at the control box end.

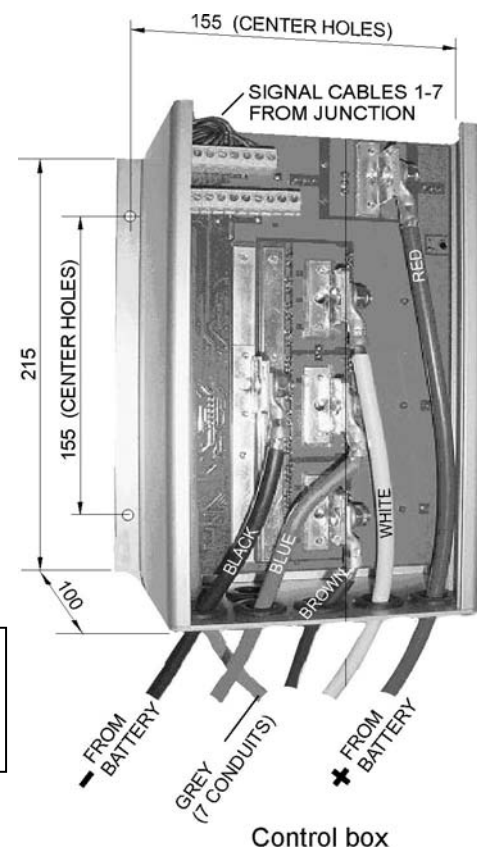

Inside the control box there are some DIP-switches. They are set at the factory and the settings must not be changed.

POWER CABLE BETWEEN ;	CABLE AREA (mm ²)	MAX LENGTH (m)				
		12V			24V	
		RA	RB	RC	RC	
MOTOR UNIT - JUNCTION BOX (FITTED AT DELIVERY)	16	5	5	5	5	
		--	--	--	--	
JUNCTION BOX - CONTROL BOX	16	8	5	--	7	
	25	12	8	5	10	
	35		12	8	15	

The signal cable between motor and control box (grey sheath) consists of 7 x 0.75 mm² cores. The seven cores are color coded.

These cables are, like the power cables, disconnected when the mast is unstepped.

Use the supplied bullet crimp terminals to make a junction close to the power cable junction box.

The terminal block in the control box is numbered from 1 to 7. Please refer to the Electrical Circuit Diagram (chapter 2.1) when connecting the cables.



Signal cables with bullet crimp terminals

2.2.3 From control box to MAIN IN-and MAIN OUT-buttons

Lead a 5 x 0.75 mm² control cable from the control box to the maneuver buttons in the cockpit. Secure the cable and attach flat crimp terminals (2.8 x 0,5 mm) to the pushbutton end of the cable.

Attach the other end to the socket terminals in the control box. Please refer to the Electrical Circuit Diagram (chapter 2.1). Note that three of the cable cores are for the maneuver function. The other two cores are for the internal button light.



MAIN IN/OUT-button

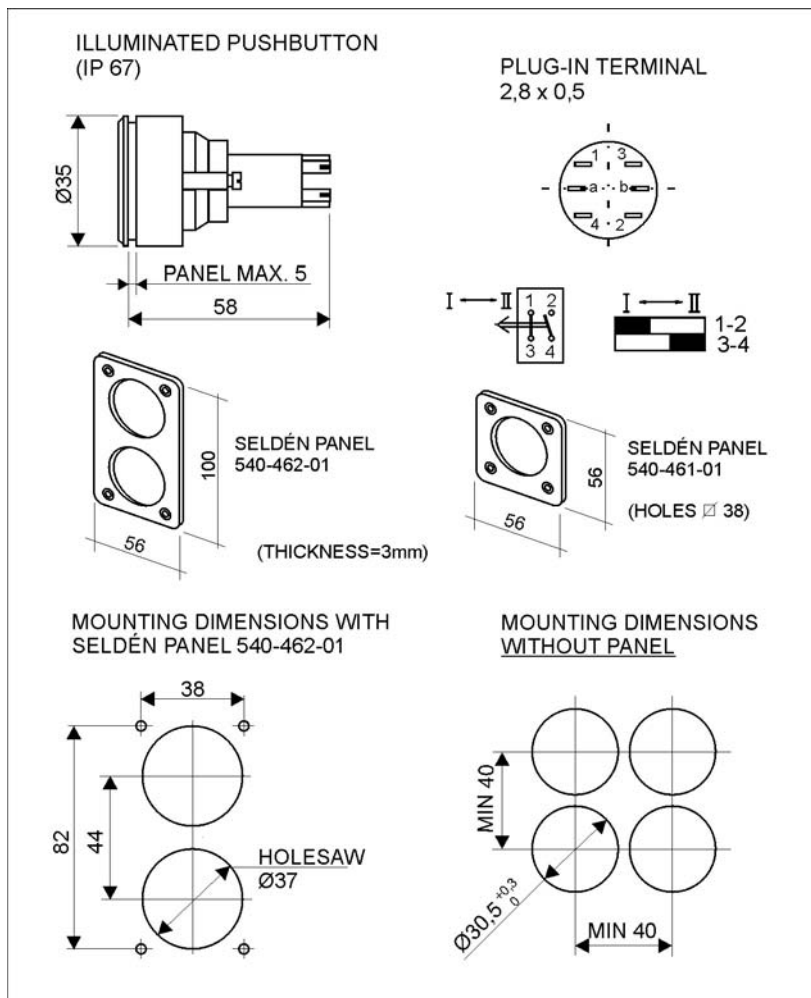

2.2.4 From control box to cabin control panel

Lead a 2 x 0.75 mm² cable from the two switches for supply in the cabin control panel and connect it at the control box end. Please refer to the Electrical Circuit Diagram, chapter 2.1.

2.2.5 From mast to junction box

When stepping the mast, beware of not damaging the four motor cables, emerging from the mast base.

Lead the three power cables (brown, white, blue) and the signal cable (grey) to the junction box and cut them to desired length. Fit ring crimp terminals (Ø8.4 mm eye) to the power cables, and apply heat-shrinkable tube for extra protection. To tighten the three M8 nuts in the junction box, use a socket wrench.

Fit crimp bullet terminals (male) to the seven signal cables. Apply some Vaseline or similar to each bullet terminal and connect them to the signal cables coming from the control box.



Beware of the color coding if the cables coming from the control box is not of the same type/color as the cables coming from the motor. To prevent the cables from being mixed up, open the drive once again and make a scheme based on the actual installed cables. **If the cables are mixed the motor might be seriously damaged.**

3 OPERATION

The instructions in chapter 3 refer to “Manual for Furling Mast TYPE RA” (595-059-E) and “Manual for Furling Mast TYPE RB Mk II/RC Mk II” (595-063-E).

There is also a reference to Sailmaker’s Guide, which you can download from Seldén’s home page (www.seldenmast.se/manuals)



The electrical furling system generates high torque in the luff extrusion and high loads in the sail. It must be operated by an experienced and qualified skipper who is aware of the dangers associated with high power deck equipment. He must ensure that all crew are aware of the equipment and the dangers associated with it.

Before testing the installation, ensure that the luff extrusion is free to rotate without restrictions. The sail should not be hoisted at this stage.

Before using the emergency gear; make sure that the MANEUVER SUPPLY SWITCH in the cabin control panel is in “OFF”-position.

3.1 Test and setup

Preparations; the mast is stepped, and the motor cables have been connected according to chapter 2. The sail is not hoisted yet.

3.1.1 Testing Rotation Direction

Press the “MAIN IN”-pushbutton in the cockpit and check that the luff extrusion rotates. Note the direction of rotation. Refer to the drawing, check that the extrusion is rotating anti-clockwise. (If a remote control is installed, parallel to the pushbuttons, also check the furl switch function now.)

Depress the “MAIN OUT”-button and check that the luff extrusion rotates clockwise. (Also check the un-furl function of the remote control)

If the rotation directions are reversed please refer to the Electrical Circuit Diagram (chapter 2.1). Then swap the spade terminals (position 3) on the pushbuttons in the cockpit, **or** swap the same cores in the control box.

Test the rotation direction again.

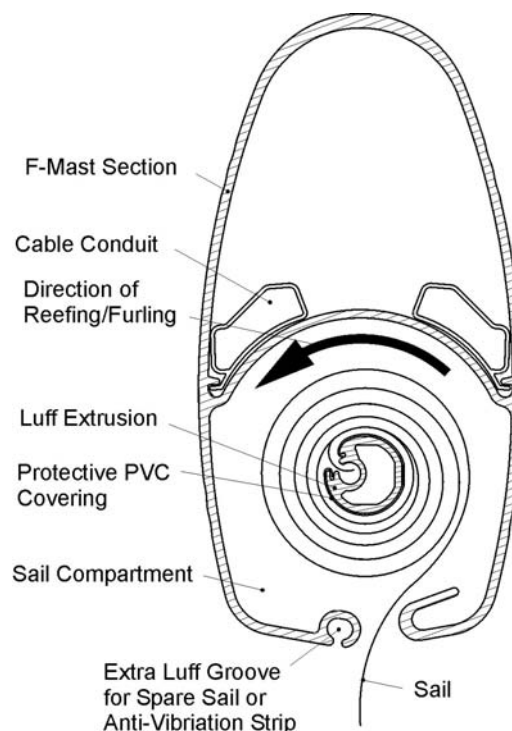

3.1.2 Testing the Emergency Gear

Before hoisting the sail we recommend to learn how the emergency gear works. You will find the part names in the illustrations of this manual (chapter 1.2, 1.7.9, 3.2.6).

First locate the maneuver supply switch
 emergency handle
 emergency handle socket
 release lever
 plunger

Then follow the instructions included in chapter 3.2.7, picture 1-9.

NOTE: If you try to wind the handle anti-clockwise (pic. 5b), without pulling the sail/outhaul line, the worm/handle socket will unscrew.

3.1.3 Fitting and Hoisting the Sail

Hoist the sail as per instructions in “Manual for Furling Mast TYPE RA” (595-059-E) or “Manual for Furling Mast TYPE RB Mk II/RC Mk II” (595-063-E).

3.1.4 Furling the sail

With the yacht pointing into the wind, furl the sail as per instructions in 3.2.2 Furling .

3.2 Un-furling and Furling the sail

3.2.1 Un-furling

- Pull the outhaul while simultaneously pressing the MAIN OUT switch.
- If the motor rolls the sail out faster than it can be pulled out with the outhaul, release the switch temporarily.
- Do not use the motor without taking in on the outhaul. The sail will jam if it is unfurled inside the mast.
- Stop the motor when the sail is fully unfurled. A red mark on the sail should indicate this position. (Please refer to Sailmaker’s guide, 595-542)
- If you continue pressing the “MAIN OUT” switch, it will result in the sail furling back onto the luff extrusion in the wrong direction.
- Foot tension must be applied with the outhaul line, not with the furling motor.

3.2.2 Furling

- Keep the aft face of the mast clear of all halyards and lines to avoid them being rolled in with the sail.
- The leech and the foot of the sail should both be fairly tight. The sail will then form a tight roll around the luff extrusion.
- Leech tension is adjusted with the topping lift and kicking strap. Foot tension is controlled with the outhaul.
- Ease off the outhaul and press the “MAIN IN” button. Lay one turn of the outhaul line around the winch, and pay out as the sail is furled. Keeping excessive on the outhaul will result in overloading the furling motor. Furl the sail until only the clew is exposed.

3.2.3 Reefing

- Follow the same procedure as for furling in.
- The mainsail can be reefed to any desired size.
- The sail will always be securely held by the permanent loaded brake in the motor unit as long as the motor is not running, or the lever for the emergency gear is not released.
- Foot tension must be applied with the outhaul line, not with the furling motor.

3.2.4 Outhaul line

We recommend a self-tailing winch for the outhaul. A rope stopper is recommended for securing.

3.2.5 Topping Lift (Spare Main Halyard) and Kicking Strap

We recommend that both topping lift and kicking strap are controlled from the cockpit. Their lines are best secured with rope clutches (stoppers). The topping lift (spare main halyard) should have a stopper-knot to prevent it inadvertently running out, escaping, and allowing the boom to fall into the cockpit. The stopper knot should be put where the line exits from the boom or stopper, and be positioned for the "lowest safe level".

(NOTE! This is not essential if a Rodkicker is used.)



3.2.6 Emergency Gear - components

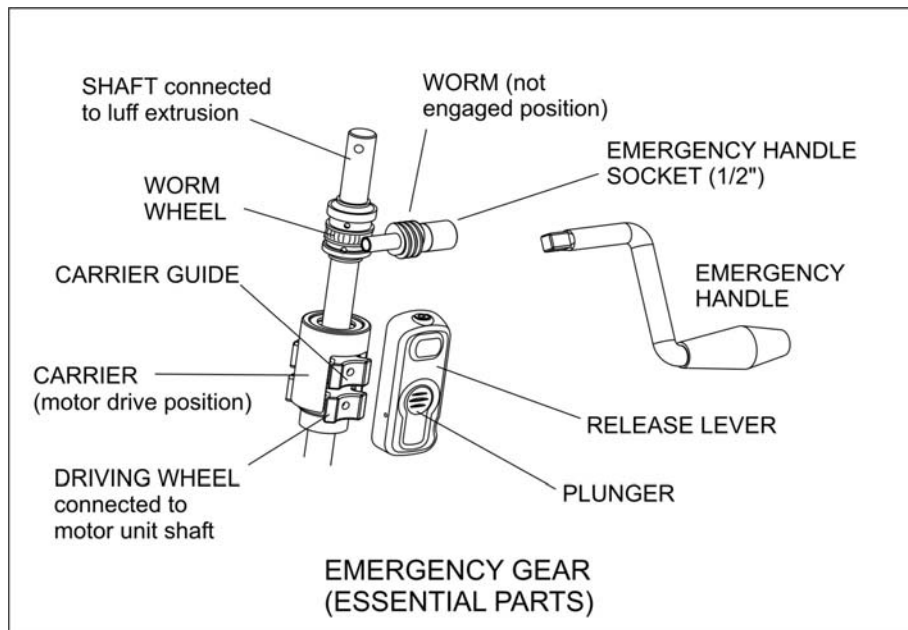

The illustration below shows the essential components of the emergency gear. Please also refer to illustrations in chapter 1.2 and 1.7.9.

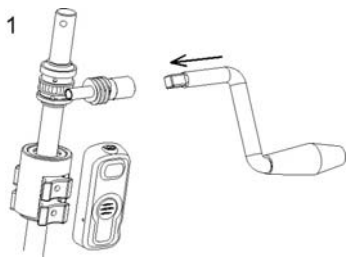
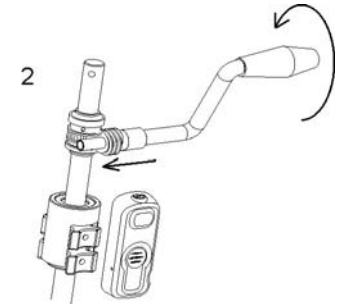
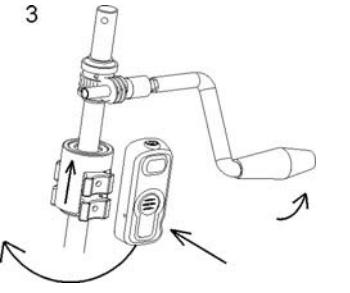
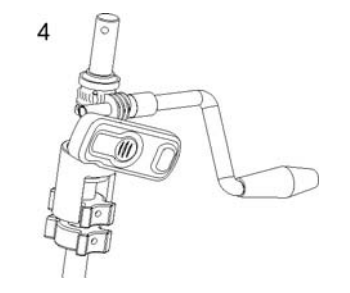

- The WORM is spring loaded to stay in outer position (not engaged).
- The worm gear has a ratio of 20:1, so it takes very little effort to turn the luff extrusion, but about 5 minutes of winding to fully stow the sail.
- The EMERGENCY HANDLE SOCKET is part of the worm and you find it on the starboard side of the mast.
- The dimension of the EMERGENCY HANDLE socket is the same as for a standard 1/2" socket wrench. This means that, instead of the handle, you could use a cordless drilling machine with a 1/2" adapter,.
- The DRIVING WHEEL is locked by the permanently loaded brake whenever the motor is not running.
- The CARRIER GUIDE is connected to the luff extrusion (via the shaft and the tack assy).
- The CARRIER connects the driving wheel and the carrier guide, when it is in low position. This means it transfers the rotation of the motor to the luff extrusion, or the torque from the luff extrusion, to the brake.
- The RELEASE LEVER lifts the carrier and disconnects the luff extrusion from the output shaft of the motor unit.
- The PLUNGER locks the release lever in motor drive position (vertical).

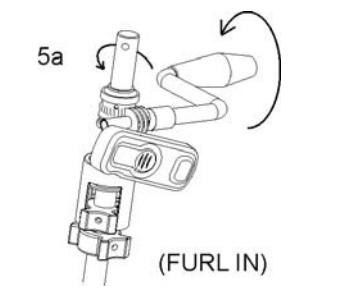

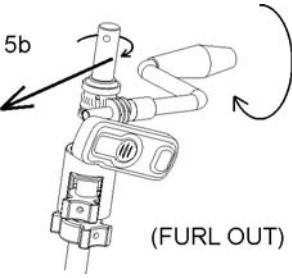
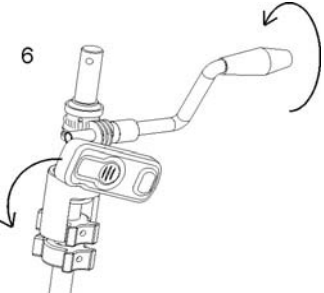
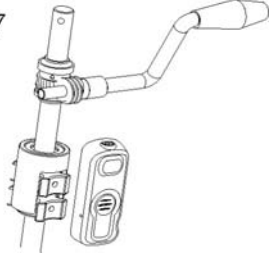
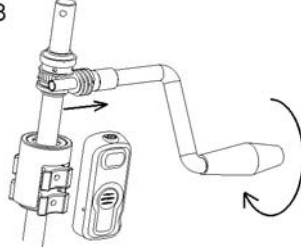

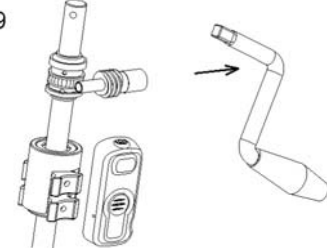
3.2.7 Manual Operation (Emergency Operation)

<p>1  Make sure that the MANEUVER SUPPLY SWITCH in the cabin control panel is in “OFF” position.</p> <p>Insert the emergency handle.</p>	
<p>2. Push the handle, and thereby the worm, towards the mast.</p> <p>At the same time wind the handle clockwise.</p> <p>The worm will now catch the threads of the worm wheel.</p> <p>Continue to wind until the handle comes to a stop (3-5 turns).</p>	
<p>3. Release the load on the carrier by forcing the handle clockwise.</p> <p>Push the plunger and turn the release lever clockwise.</p>	
<p>4. The carrier is now in its upper position and there is no connection between luff extrusion and motor/brake.</p> <p>The self-locking worm gear will now take the torque load from the luff extrusion. As long as the worm is engaged the system is self-locked.</p>	
<p>5a. Furl: Start winding the handle <u>clockwise</u> and carefully pay out the outhaul line.</p> <p><u>When the sail is reefed (or fully stowed) continue to follow the instructions 6-9, before tighten the outhaul.</u></p> <p> THE WORM GEAR MUST NOT BE ALLOWED TO TAKE THE TORQUE LOAD WHEN SAILING.</p>	 <p>(FURL IN)</p>

<p>5b. Un-furl at windy conditions: The sail will be pulled out by the outhaul and the wind. At the same time wind the handle <u>anti-clockwise</u> to override the self locking effect of the gear.</p> <p>When the sail is out enough, continue to follow the instructions 6-9 before tightening the outhaul.</p> <p> WINDING THE HANDLE WITHOUT PULLING THE SAIL WILL MAKE THE WORM COME FREE AND DISENGAGE THE SELFLOCKING GEAR.</p> <p>(To un-furl at light wind conditions refer to instructions in chapter 3.2.8)</p>	
<p>6. Turn the release lever gently and at the same time wind the handle <u>clockwise</u>.</p> <p>The carrier will now search the driving wheel for connection. When the carrier is engaged the release lever will come back to the vertical position.</p> <p>(This will require at maximum half a turn of the luff extrusion = 10 turns on the handle)</p>	
<p>7. When the release lever is back in the vertical position, check that it is locked by the plunger.</p> <p>Luff extrusion and motor/brake are connected.</p> <p>The worm gear is still engaged.</p>	
<p>8. Wind the handle anti-clockwise to dis-engage the worm gear.</p>	
<p>9. Remove the handle.</p> <p> NEVER PUT THE MANEUVER SUPPLY SWITCH IN THE "ON" POSITION BEFORE THE HANDLE IS REMOVED.</p>	

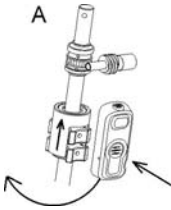
3.2.8 Manual Operation, Un-furling in light winds

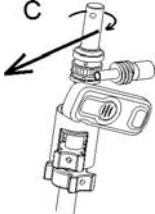
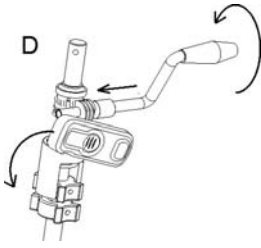
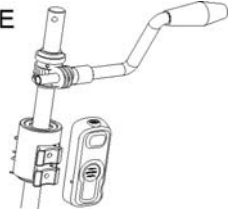
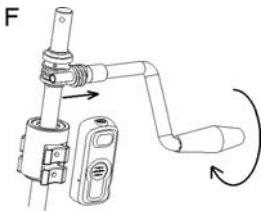
In light wind conditions it is possible to un-furl the sail faster using the method described below.

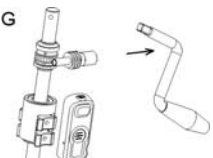
<p>A  Make sure that the MANEUVER SUPPLY SWITCH in the cabin control panel is in “OFF” position.</p> <p>Pay out the outhaul line.</p> <p>Push the plunger and turn the release lever clockwise.</p>	
<p>B. The motor/brake is disconnected as the carrier is in its upper position.</p> <p>The self locking gear is not engaged.</p>	
<p>C. If the sail is fully stowed, pull the outhaul line.</p> <p>If the sail is reefed, either the wind will roll it out, or you have to help by pulling the outhaul line.</p> <p>YOU HAVE NO POSSIBILITY TO CONTROL THE ... UN-FURLING SPEED WITH THIS METHOD.</p>	
<p>D. Insert the emergency handle, push and wind it <u>clockwise</u> until the worm gear is engaged.</p> <p>Turn the release lever gently and at the same time continue to wind the handle <u>clockwise</u>.</p> <p>The carrier will now search the driving wheel for connection. When the carrier is engaged the release lever will come back to the vertical position. (This will require at maximum half a turn of the luff extrusion = 10 turns on the handle)</p>	
<p>E. When the release lever is back in the vertical position, check that it is locked by the plunger.</p> <p>Luff extrusion and motor/brake are now connected.</p> <p>The worm gear is still engaged.</p>	
<p>F. Wind the handle anti-clockwise to dis-engage the worm gear.</p>	
<p>G. Remove the handle.</p> <p> NEVER PUT THE MANEUVER SUPPLY SWITCH IN “ON” POSITION BEFORE THE HANDLE IS REMOVED.</p>	

4 MAINTENANCE

4.1 Top and halyard swivel

Please refer to the Manual for Furling mast 595-059 or 595-063.

4.2 Furling mast *ELECTRIC* – *motor unit and emergency gear house*

4.2.1 Periodic maintenance

The unit is designed for coastal/offshore climate. However, we recommend to rinse the unit with freshwater when rinsing the deck. Use the luff groove and let freshwater flow over the unit from above.

4.2.2 Greasing

The lower bearings of the emergency gear house contain composite bearing balls and should not be greased.

The upper bearing of the emergency gear house should be greased once a year. Apply the grease through the Ø12 mm greasing hole on port side of the mast, just below the boom bracket.

Use the included grease tube,
Seldén partnumber 312-501.
(Mobile Grease XPH 103)

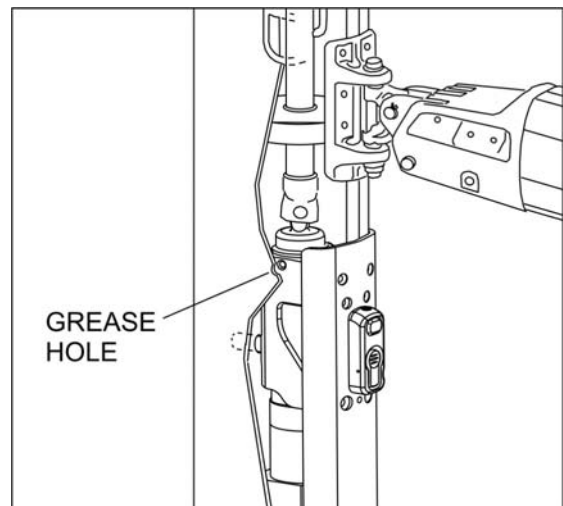

5 INSTALLATION OF A RETRO-FIT FURLING MAST ELECTRIC

Chapter 5 is a guide how to replace a Seldén Manual Furling Gear with a Furling Mast Electric. Electrical installations are described in chapter 2.



The installation of a Furling Mast Electric, described in this chapter, requires knowledge and practical experience of similar work. A hole or cut out made in the wrong position or manner can weaken the mast and make it necessary to exchange the whole mast extrusion.

5.1 Preparations

Please read the instructions through carefully before starting the work. Note the actual mast section size and type of system (ex: F246, RB). Take some minutes to mark out the dimensions in the tables and below, which are specific for your mast. The template is unique for mast section size and type of system (RA, RB etc). Check that you have the appropriate template before starting the work.

The installation can be done on a stepped mast, but we strongly advice you to un-step the mast and put it on trestles. This will facilitate the work.









If the new emergency handle interferes with a winch, a cleat or any other existing equipment on the mast, this equipment has to be moved (see chapter 5.6 for the position of the emergency handle)

Or you could use an extender for the handle. If you use an extender we strongly recommend you to get one exclusive for this purpose and fix it to the handle with some tape. Then it will always be ready for use. The handle has a standard 1/2" socket wrench fitting.



5.1.1 Checklist

In addition to the details included in the control pack (compare 1.5 Checklist) you should have received the following parts .

Y	Description	Qty	Seldén part number/ notes
<input type="checkbox"/>	Motor unit, including cables 	1	Specific for system (RA, RB etc) and voltage 12 or 24.
<input type="checkbox"/>	Emergency gear 	1	540-607-01 RB/RC F228-F305, R324
<input type="checkbox"/>	Cover Assy 	1	Specific for mast section size (F228, F246 etc) Screws, rivets and backing plates in separate plastic bag (backing plates are not used for R324)
<input type="checkbox"/>	Tack Assy (including locking tube) 	1	Specific for system (RA, RB etc) and mast section size (F228, F246 etc)
<input type="checkbox"/>	Sealing kit 	1	319-794-01 for RB and RC type (only for keelstepped)
<input type="checkbox"/>	Template for cut out 	1	Specific for cover assy
<input type="checkbox"/>	Cover Ø44 		319-609
<input type="checkbox"/>	Loctite (3ml) 	1	312-305 locking adhesive

5.1.2 Tools

Special tools required;

Allen keys, Torx keys (up to T50)

Hole saw Ø22, Ø24, Ø39 mm

For a keelstepped mast; hole saw Ø50 mm including one or two extenders depending on the boom height

5.2 Definitions

5.2.1 Definition of B-line

In the instructions some dimensions refer to the B-LINE. For F-masts F228-F305 the B-line is a groove on the port and starboard side of the mast. It is easy to identify.

On R324 there is a pattern of grooves on the sides of the mast. Please refer to the illustration and identify the B-line for R324 as the fourth groove, start counting from aft.

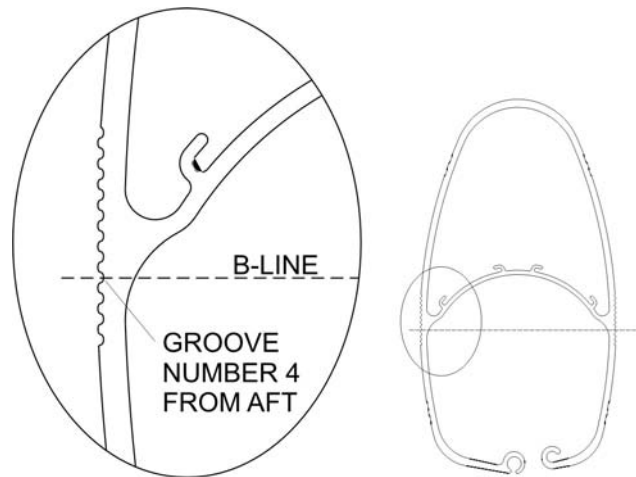

5.2.2 Definition of directions

All illustrations, if nothing else is declared, show the starboard side of the mast, this means that the top of the mast is to the right.

5.3 Dismounting the manual gear

1. Please refer to Manual for Furling Mast 595-063 or 595-059 when dismantling the existing manually gear.



2. Remove the two existing backing plates by drilling away the rivets.



5.4 Using the template

3. Check the width of the luff groove. Put a wooden or plastic wedge in the groove to open it, or tighten a rope around the mast to close the groove. Later, when the cover is mounted this will guide the groove to a proper width.

Mast section size	Luff groove (mm)
F194 – F246	15
F265 – F305	17
R324	15

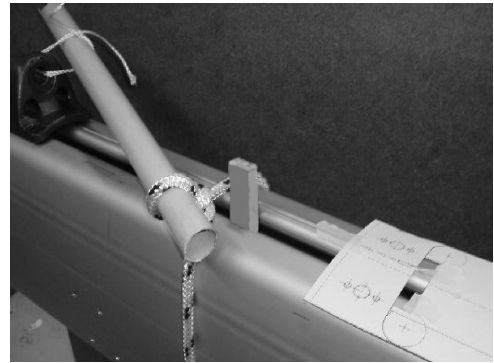

4. Cut out the template from the included A2 sheet and put it in position with pieces of tape at the ends. You find the upper edge of the old cut and the Tri Sail Track on the template. Use these as references.

Difference between upper edge of old and new cut is 3 mm for F228-246, 33 mm for F265-324 (as in the picture)



5. Apply additional pieces of tape to fix the template and to make it follow the mast curve. Check the reference points once again.

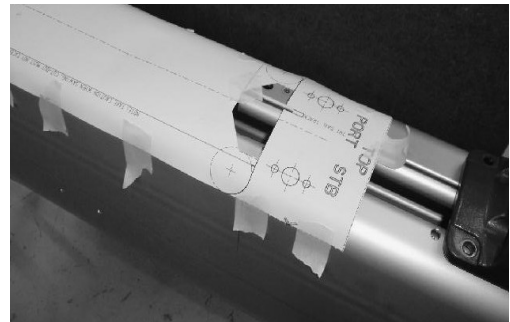

6. Mark out the upper edge of the cut.



7. Mark out the lower edge of the cut.

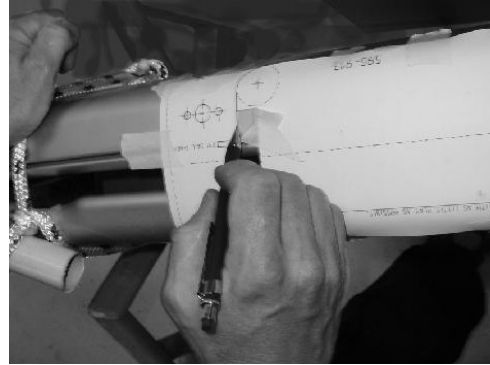

8. Put a mark near the ends of the cut on starboard and port side.

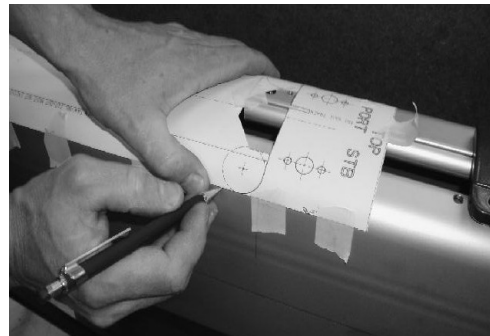

9. Mark the center of the four Ø30 circles with a centre punch.

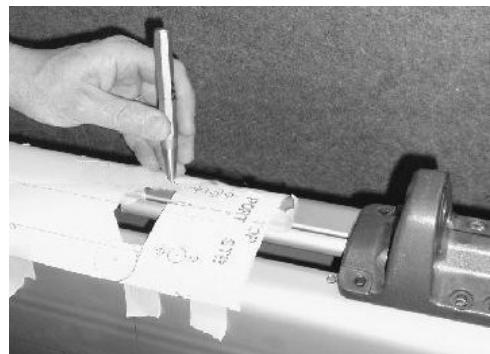

10. Remove the template.

11. Fix a ruler with tape and complete the cutting line on starboard and port side.



5.5 Cutting out for the Furling Mast ELECTRIC

12. Pre-drill ($\varnothing 3$ mm) and use a $\varnothing 24$ mm hole saw for the four corners of the cut. (**Do not use $\varnothing 30$ mm**).

Keep the hole saw axis normal to the mast surface.



13. Use a jig saw and make the cut out. Keep the saw normal to the mast surface. Be careful not to make the cut too long. (It is better to make it one mm too short and file off the upper and lower surfaces to make the cover fit snugly into the cut, see pct. 18 - 20 below.)



14. Use a file to round the corners close to $\varnothing 30$ mm.

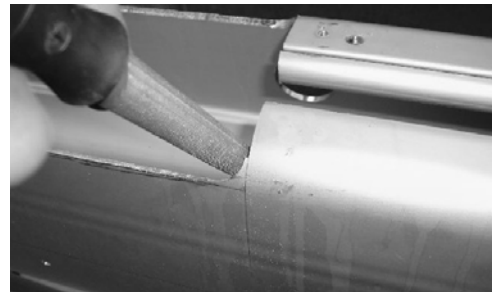

15. Flatten the cut surfaces with a file.

Deburr the edges but do not round them off.

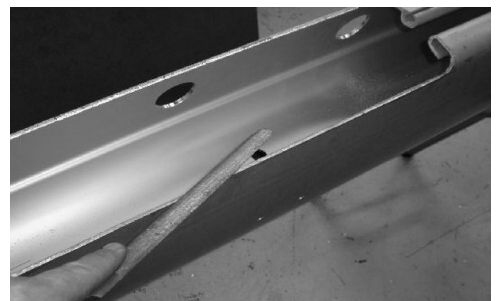

16. Check the distance between the inner edges of the mast extrusion. Refer to the table below.

Mast section size	Distance (mm)
F194 – F246	90 - 91.5
F265 – F305	104.5 -105
R324	120 120.5



17. File off little by little on both edges until you achieve the appropriate distance (keep the file vertical).



18. Flatten and deburr the upper and lower surfaces of the cut.



19. Remove the wedge/rope that was applied to keep the luff groove width.

20. Try the cover in the cut out. Put it down parallel to the mast. It will certainly not fit at the first try. File little by little on the lower edge of the cut until the cover fits snugly into the cut. As the cover will take the compression load, which appears when the mast is bent backwards
The gap should not exceed 0.5 mm.

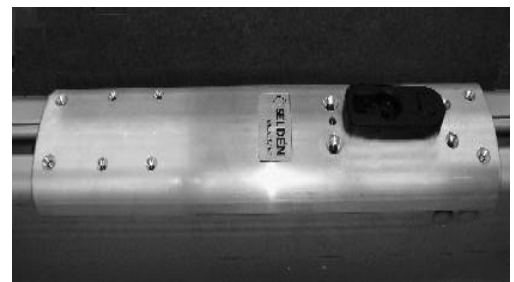

21. Mark out and punch the center of the four holding screws (two at each end of the cover). Remove the cover.
F228-F305; Drill four Ø3 mm guiding holes and then four Ø12mm holes.
R324; Pre-drill (Ø3 mm), drill Ø6.6 mm and make M8-threads.
The holes should be normal to the mast surface.



22. **F228-F305**; Find the four backing plates (508-494) together with the 8 rivets. Put the backing plates in position from outside the mast and use them as templates when punching the center for the rivet holes. Drill these 8 holes (Ø4.9 mm) and countersink to Ø8 mm for the rivets.

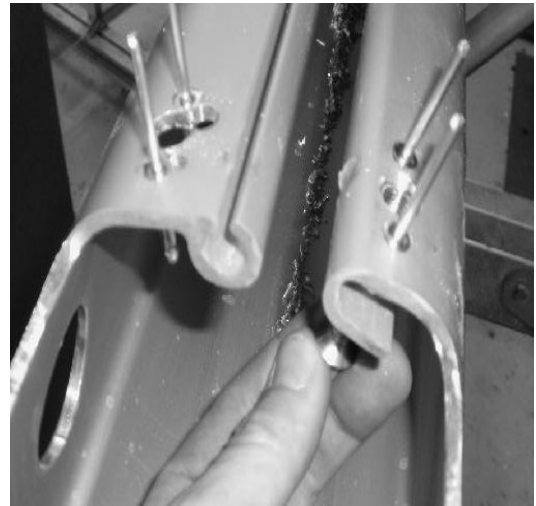

23. **F228-F305**; Mount the backing plates from underneath and apply the rivets. Guide the backing plates into position (starboard side) with a M8-bolt.

NOTE: On starboard side of the mast the Ø12 and the Ø4.9 holes go through the luff groove flange.

24. Do not forget to punch out the rivet mandrel heads.

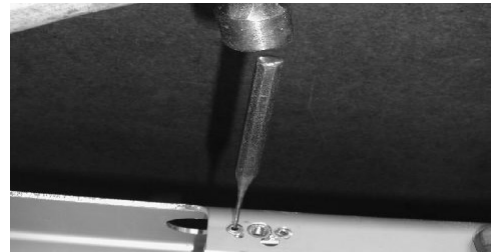

5.6 Cutting out for the emergency handle socket

25. Fix an A4 paper along the B-line and transfer the top of cut to the starboard side of the mast. Pick the proper X-dimension from the table and punch the center of the hole.

Mast section size	X (mm)
F228	53.5
F246 and F265	57.5
F286	60.5
F305	62.5
R324***	62

***B-line on R324, see definition, chapter 5.2.1

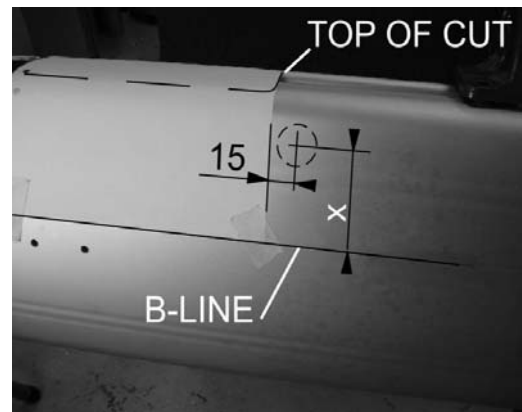

26. Pre-drill (Ø3 mm) and then use a Ø24 mm hole saw to make the cut.

The cut out should be made 90° to the longitude plane of the mast.

Chamfer the edges of the hole.

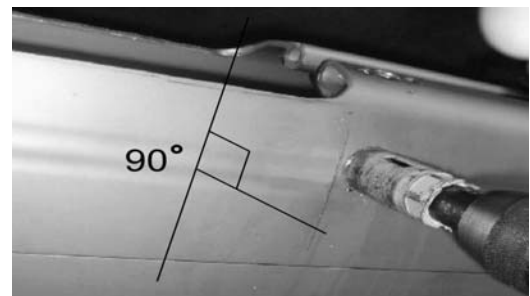

5.7 Cutting out for the torsion pin

27. Use a set square to transfer the upper edge of the cut out down to the center wall of the mast extrusion. Put a mark at 90 mm.

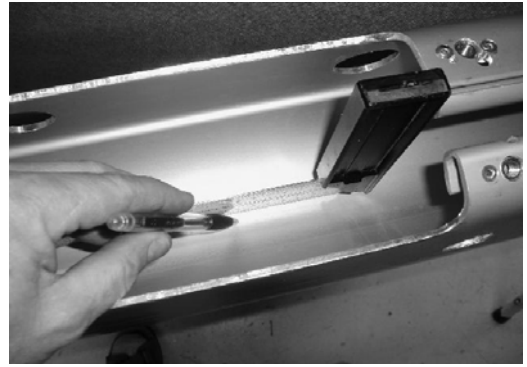

28. Check the distance from B-line to starboard and port edge of the cut out. They should be equal.

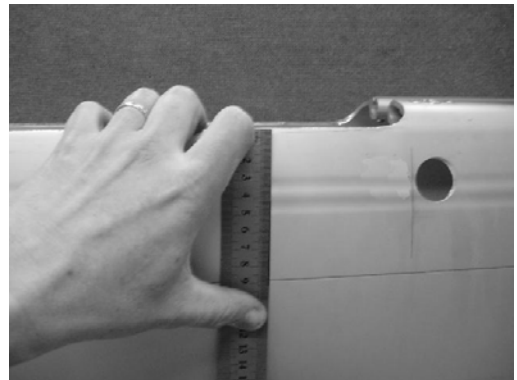

29. Prepare a ruler with a fixed stop.



30. Adjust the stop so the ruler end is near the middle of the center wall inside the mast.



31. Make a line at the end of the ruler. Mirror the arrangement and make another line. You find the center in the middle between the two marks.

NOTE: Using this method to determine the center requires that the distances from B-line to the cut out edges are equal. See illustration 28.

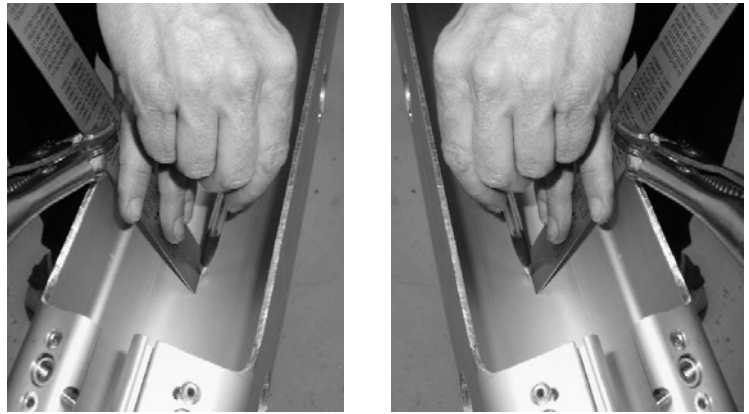

32. Punch, pre-drill ($\varnothing 3\text{mm}$) and use a 22 mm hole saw to make the cut for the torsion pin of the emergency gear house.

Enlarge the hole approximately 2 mm upwards and 2 mm downwards with a file. Do not increase the width (22mm)

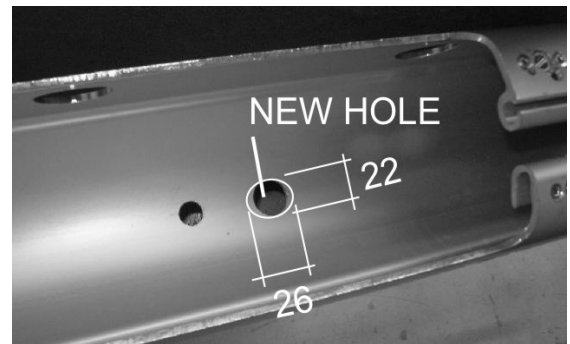

5.8 Access hole for greasing the bearing

33. Transfer the top of cut to the port side of the mast. Mark out, punch and pre-drill ($\varnothing 3\text{ mm}$). Finally make a $\varnothing 12\text{ mm}$ access hole for greasing the upper bearing in the emergency gear house. (NOTE: For F228 and F246 the old $\varnothing 39$ grease hole is used.)

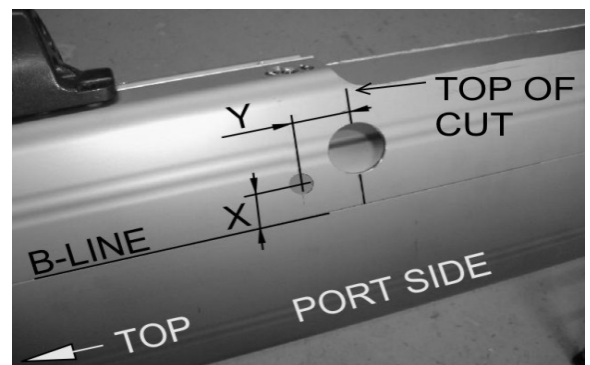

Mast sect. size	Y (mm)	X (mm)
F228 No cut	xxx	xxx
F246 No cut	xxx	xxx
F265	37	30
F286	37	33
F305	37	35
R324***	37	33

***B-line on R324, see definition, chapter 5.2.1

5.9 Access hole for the clevis pin

34. Transfer the top of the motor cut out to the starboard side of the mast. Mark out, punch and pre-drill ($\varnothing 3$ mm). Finally make a $\varnothing 39$ mm access hole for the clevis pin in the adapter. Deburr the edges of the hole.
(Cover 319-609 fits in the $\varnothing 39$ mm hole)

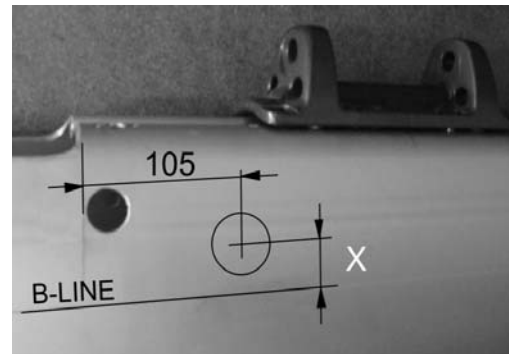

Mast sect. size	X (mm)
F228	25
F246	30
F265	30
F286	33
F305	35
R324***	33

***B-line on R324, see definition, chapter 5.2.1

5.10 Prepare for the cable sealing (keelstepped masts only)

5.10.1 Standard procedure

The cable sealing for a keelstepped mast is designed to allow mounting and dismantling of the motor several times.

R324 has another type of sealing.

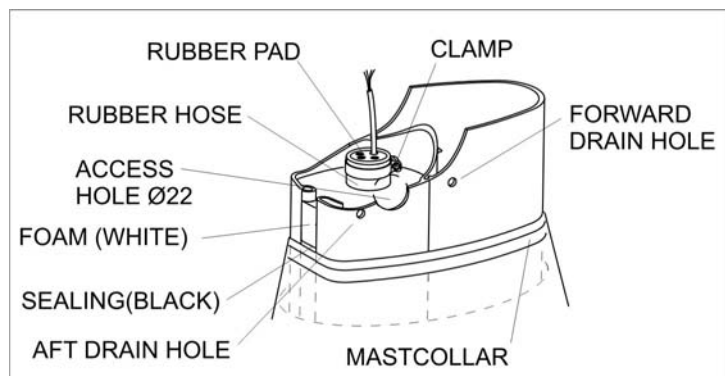

35. Pick the X-dimension from the table below.

Mast section size	X (mm)
F228	20
F246 and F265	25
F286 and F305	30
R324	35

***B-line on R324, see definition, chapter 5.2.1

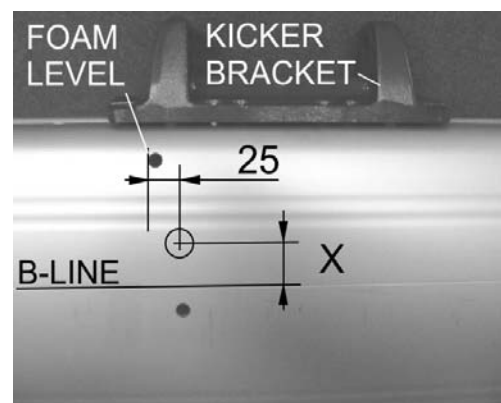

Mark out the access hole on starboard side of the mast. Center punch, pre-drill ($\varnothing 3$ mm) and complete the cut out with a $\varnothing 22$ mm hole saw. Deburr the edges of the hole.

36. Use the Ø50 mm hole saw together with extenders to make a cut through the aft internal foam mast seal. Make the cut close to the middle of the compartment.

On F228-305 you drill through 50 mm of white foam, then 35 mm of black Sikaflex and finally another layer of 55 mm white foam.

On R324 you drill through 80 mm of black ethafoam.

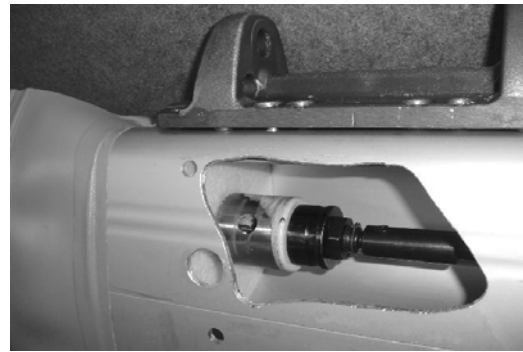

37. Put the hose clamp at the top end of the short rubber hose and tighten enough to make it stay in position. Apply some Sikaflex (included) on the lower part of the hose and inside the Ø50 mm hole.

38 Reach through the motor cut out and screw/push the hose through the Ø50 mm hole in the sealing. Stop when 25-30 mm of the hose is still above the upper white foam level. On R324-masts we recommend that some extra Sikaflex is added when the hose is in position (refer to pct. 54 for final position of the hose).

(If you do not reach from the motor cut out to the sealing level you can extend the piece of hose by inserting a rod or tube and then tighten the hose clamp.)

5.10.2 Cables emerging above deck on a keelstepped mast.

39 An alternative method is to lead the cables above deck, which excludes work on the internal sealing of the mast.

Instead of the access hole (5.9.1 pct. 34), make a Ø25 mm hole for a protection hose and lead the cables out on deck, and into a swan-neck or similar.

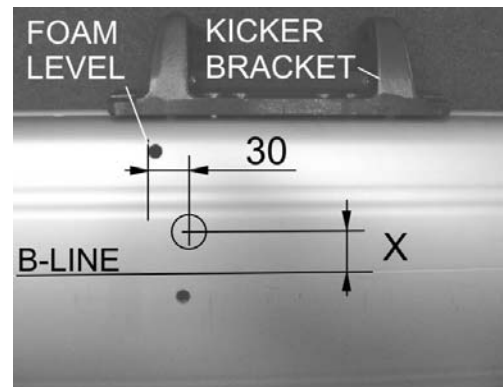

Pick the X-dimension from the table below and mark the center of the cable hole.

Mast section size	X (mm)
F228	20
F246 and F265	25
F286 and F305	30
R324	35

***B-line on R324, see definition chapter 5.2.1

Mark out the cable hole on starboard side of the mast. Center punch, pre-drill (Ø3mm) and complete the cut out with a Ø25 mm hole saw. Deburr the edges of the hole.

5.11 Cutting the torsion pin of the emergency gear house

40

Mast section size	Y (mm)
F228	10
F246	13
F265	18
F286	23
F305	27
R324 NO CUT	(35)



41 Mark the length of the torsion pin, cut and deburr the edges. The dimension Y is received from the table above.



5.12 Mounting the motor unit

42 The following screws are used to install the motor unit.

	Qty	Screw type	Screw length (mm) for actual mast section					
			F228 (RB)	F246	F265	F286	F305	R324
A	1	MC6S 8 x	30	30	30	30	30	30
B	2	MFT 8 x	25	25	40	40	50	50
C	2	MFT 10 x	50	60	60	70	70	80
D	4	MFT 8 x	16	16	16	16	16	16
E	2	MFT 6 x	30	30	40	45	50	60

43 Please find and identify the screws for later use.



44 All masts: Dismount the old tack assembly and the locking tube.

F265-R324: Mount the new locking tube and then the tack assembly. Turn the tack assembly several turns until it reaches its upper position. (remove the clevis pin from the adapter before inserting the tack assembly)

F228-F246: The new locking tube and the tack assembly will be mounted later.



45 Deckstepped masts:

Lead the four motor cables into the cut, guide them and let them emerge through one of the aft holes in the mast heel.

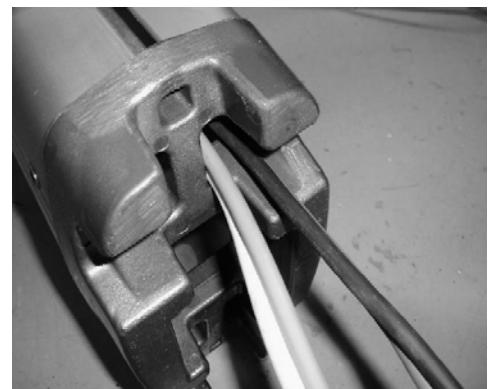

46 Keelstepped masts:

Take a measurement with the motor and cables still outside the mast and mark out the position for the rubber cable seal.

Lead the four cables through the cable seal. Use water with washing-up liquid to facilitate the process. Apply a few layers of tape to prevent the cable seal from sliding.

Lead the four motor cables into the motor cut out and guide them through the rubber hose in the internal sealing at deck level. Let them emerge through one of the aft holes in the mast heel. Use a thin messenger line.

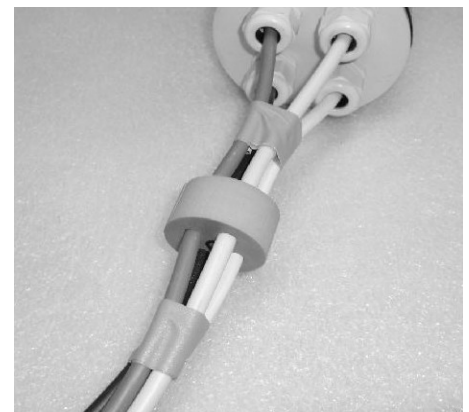

47 Put a cloth inside the mast for protection and insert the motor into the cut out. Which end you insert first depends on the mast section size. See the notes in the illustrations.

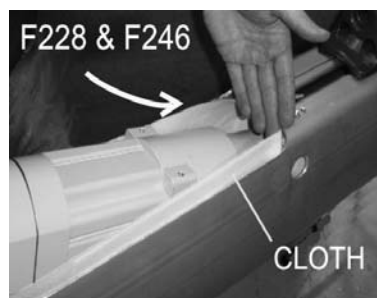

48 Deckstepped: Move the motor downwards to make space to insert the emergency gear house.

Keelstepped: Guide the rubber cable seal down into the hose in the internal sealing. Put the motor in position and confirm that the cable seal is at the level of the hose edge. Now move the motor a little more downwards to make space to insert the emergency gear house.

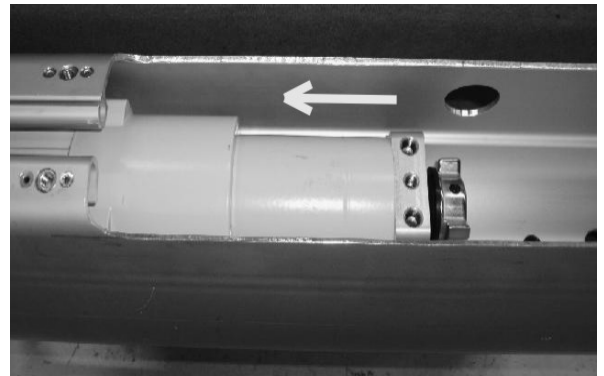

49 F228 – F246

49.1 Mount the new locking tube.

49.2 Mount the tack assembly.

Turn the tack assembly several turns until it reaches its upper position. (remove the clevis pin from the adapter before inserting the tack assembly)



50 Insert the gear house, top first, and adjust it so the torsion pin fits in the Ø22 mm hole.



51 Slide the motor towards the gear house. Apply grease on screw A (MC6S 8), insert, tighten moderately and loosen 1 turn. Use an allen key.



52 Push the fork towards the mast base (the carrier should now connect the carrier guide and the driving wheel, see chapter 3.2.6.) Put the cover in position and make sure the excentric pin fits in the long hole of the fork.

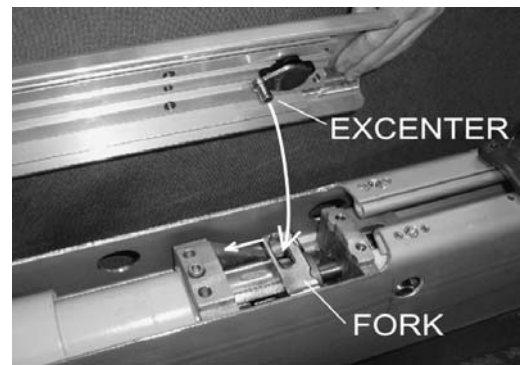

53 Apply grease on the two C-screws (MFT10), insert but do not tighten yet. Use a torx key.

(There are self-locking insert threads in the top part of the motor unit)



54 Keelstepped; First check through the access hole and make sure that the cable seal is in the same level as the hose. adjust it if necessary and then use a flexible screwdriver to tighten the hose clamp.



55 Apply grease on the two B-screws (MFT8), insert but do not tighten yet. Use a torx key.

(Self locking insert threads in gear house)



56 Apply loctite on the two E-screws (MFT6), insert but do not tighten yet. Use a torx key.
NOTE: The cover for F265 has two pair of countersunk holes for the E-screws. Use the top pair for RB-system and the bottom pair for RC-system.

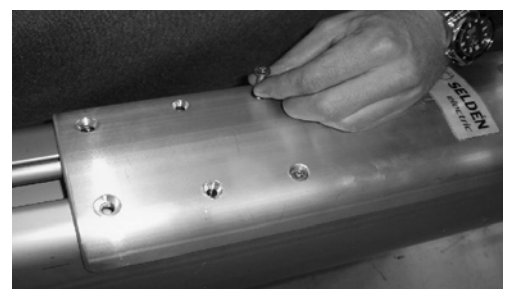

57 F228-F305; Apply **loctite** on the four D-screws (MFT8), insert but do not tighten yet. Use a torx key.

R324: Apply **corrosion preventive coating** (Tectyl, Dinitrol or similar). Use paste, not the thin aerosol type.

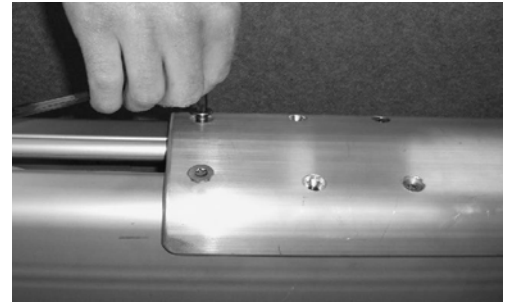

58 To ensure the parts positioned in alignment, follow the order below when you tighten the screws.

- 1) B1, B2, C1, C2, E1, E2; tighten moderately
- ..2) B1, B2, C1, C2, E1, E2; tighten hard
- ..3) Tighten screw A
- ..4) Tighten the D-screws hard

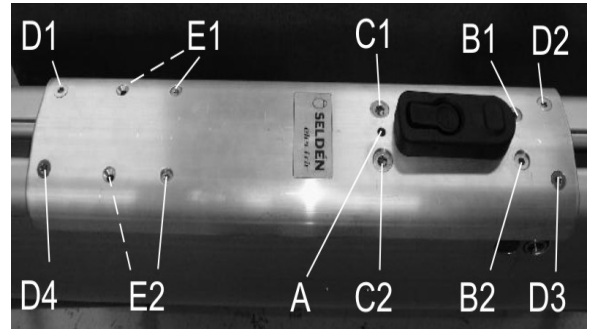

59 Turn the tack assembly downwards to make the adapter fit over the shaft of the emergency gear house. Guide the adapter through the luff groove or through the access hole on starboard side

Please refer to Manual for Furling Mast 595-063 or 595-059 from here (tensioning the luff extrusion etc).

